

Case Study: Euklid CAD/CAM AG selects ModuleWorks Simulation technology

EUKLID

Solutions for CAD/CAM



Introduction

Simulation of the CAM process has come into its own in recent years and is now a lynchpin of most major CAM systems on the market today. Initially simulation tended to be focussed on stock removal but in recent years has been extended to include full machine tool motion.

EUKLID, from Switzerland, is a well known CAM system specialising in the design and manufacture of mould tools and dies. It includes sophisticated CAM strategies for 3-5 axis machining including high speed cutting and 5-Axis simultaneous machining.

Back in 2008, Euklid realised the growing demand for Simulation technology from their customers and decided this needed to be a part of the Euklid product range. Customers were pushing harder for right first time and looking to use simulation technology to help optimise tool paths and eliminate programming errors (which may result in expensive collisions).

This case study looks at how they went about adding Simulation to EUKLID, from selection through implementation and launch.

Make or Buy

Euklid was aware that simulation was a complex technology, usually provided by component technology so early on it was decided that they would seek to use component technology to provide simulation.

In looking for a solution, Euklid evaluated a number of external providers and selected ModuleWorks as simulation partner. The decision came down to a number of factors:-

- Time to market
- Ease of implementation and support provided
- Size and expertise of the ModuleWorks team

ModuleWorks strong manufacturing heritage was also a consideration with the Euklid team happy that ModuleWorks understood their application and requirements of simulation technology.

An additional benefit of this route was that the majority of the Euklid development team was able to continue to focus on other important areas, adding to the strength of the overall product.

Yavuz Murtezaoglu, Managing Director for ModuleWorks says, “The make or buy decision is always an important part of the decision to use component software. In this respect, the software industry in many years behind other industries, such as car manufacturing, where buying in components is often the default choice. However, we have seen a transition over the last few years, in that most CAD/CAM providers are now happy to accept that everything cannot be developed in-house and they have become much more open to using best-in-class component software.”

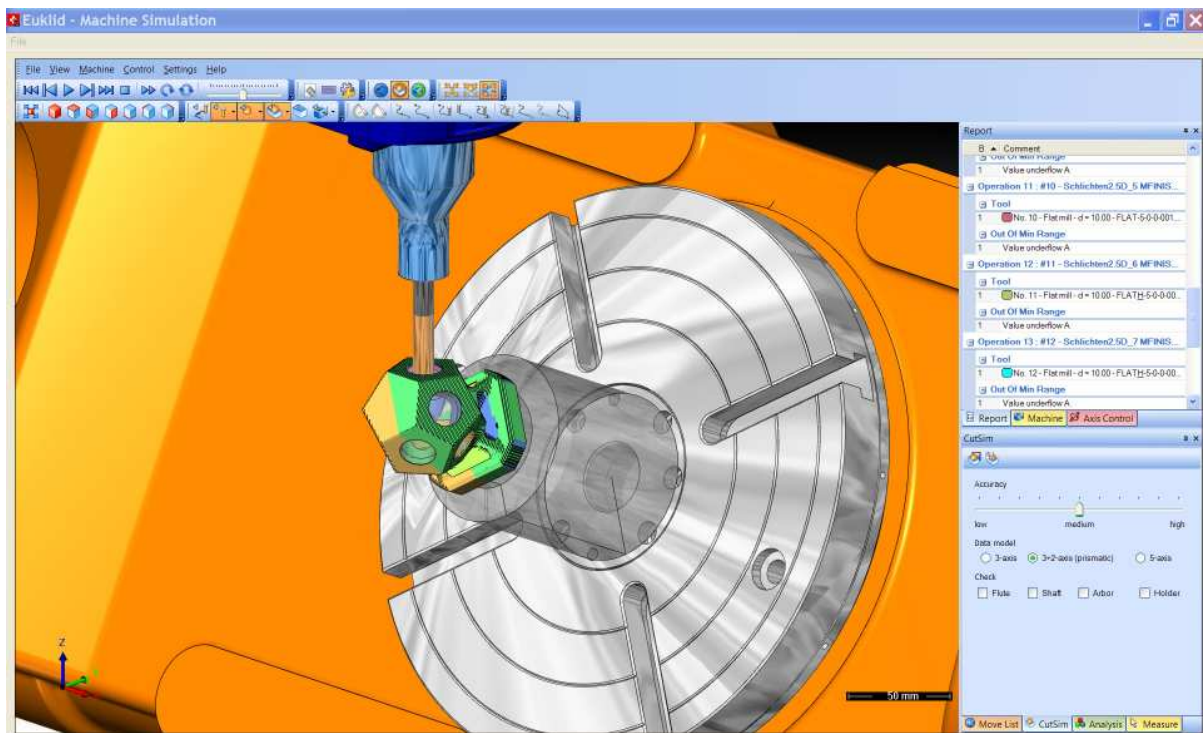

Implementation

Implementation was a relatively smooth affair with ModuleWorks able to provide a high level of technical support and advise on the best integration strategies to meet Euklid’s development goals.

Euklid elected to use the inbuilt tools to create machine kinematics which helped build target machine tools quickly and efficiently. Following on from this it was case of taking EUKLID tool paths and passing them to the ModuleWorks simulation tools; again EUKLID was able to utilise the inbuilt kinematic solvers to take their internal toolpaths and flavour them for the target machine.

Integration, testing and other areas such as installation were complete during the course of one development cycle, around 6 months from the start of the process to the sign off for the completed product.

Depending on integration strategy, the development cycle can be longer or shorter than the time quoted above. As a rule of thumb, the tighter and more embedded the integration, the greater the overall effort involved.

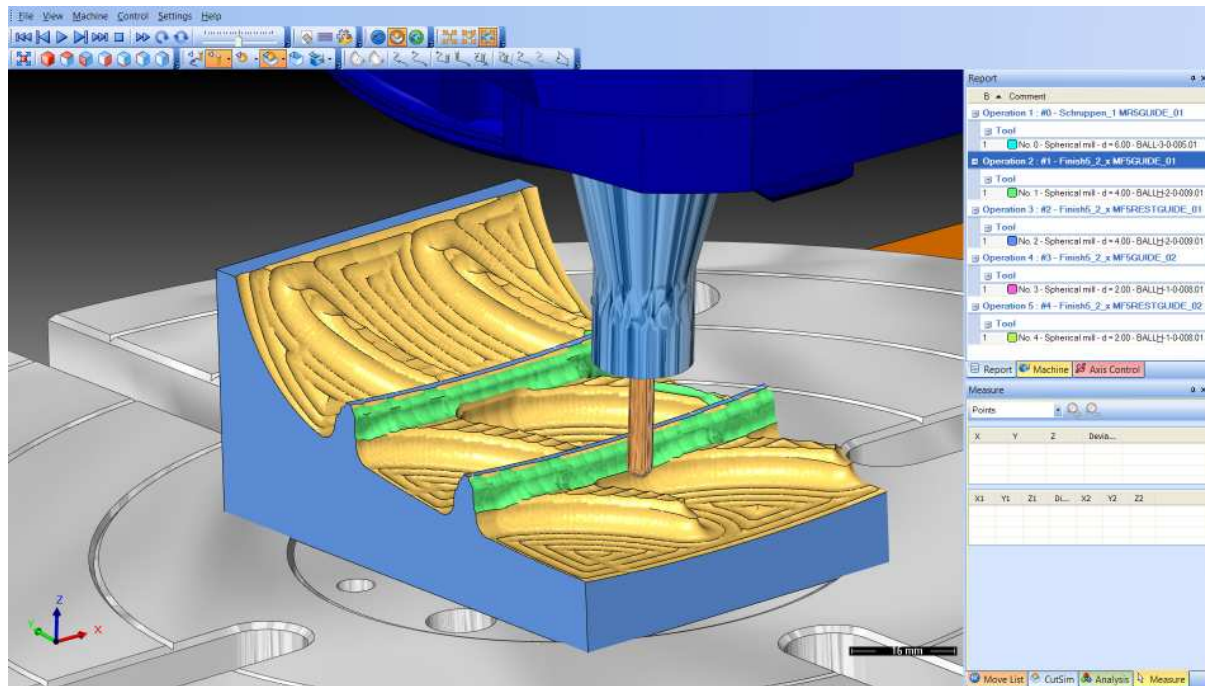

A Successful Release

The EUKLID simulation was released in 2009 and enthusiastically received by the EUKLID user base. The programming of 3-5 axis tool paths and the machining simulation within EUKLID complement one another as an optimum. Customers may have an easy access to the 5 axis programming and they were able to quickly build their own machine, either by tailoring one the range of many supplied machines or, with Euklid's support, building new machines using the ModuleWorks kinematic definition tools.

Heribert Kaiser, Sales Director for Euklid comments "Our customers immediately saw the added value provided by our simulation software. In many cases they reported that they had improved the programming process and part quality and that their operators were more confident working with the final NC program. We saw a positive impact on sales and our customers were happy with the additional tools so this was a true win-win situation".

Ongoing Partnership

Euklid has continued to leverage ModuleWorks simulation technology to provide further productivity improvements to their customers. Euklid and ModuleWorks have formed a successful partnership to maintain, support and enhance the product with each release and opened the possibility of further collaboration on other projects in future.

About Euklid

With almost 40 year of experience in the development and operation of the CAD/CAM system EUKLID, the Euklid CAD/CAM AG is an experienced and leading provider of solutions for the die and mould industry. It integrates with CAD, powerful NC-programming capabilities in the CAM part, and a full range of postprocessors all the steps to the milling machine. The range of applications extends from 5- and 3-axis milling of complex parts to drilling and milling in 2.5 axis. It is the goal of the Euklid CAD/CAM AG to optimise the production process of their clients with the most recent CAD/CAM technologies with respect to quality, efficiency and speediness, while maintaining the highest standards with respect to precision and complexity.

(For more information, visit www.euklid-cadcam.com).

About ModuleWorks

ModuleWorks is a software component provider for the CAD/CAM industry. ModuleWorks' expertise in 5-Axis simultaneous machining is recognised throughout the CAM industry and its software components and development services are used in many of the leading CAM vendors in the market today. ModuleWorks 5-Axis software has been used to manufacture complex 5-axis parts for more than 10 years and now has over 2000 users worldwide.